

INSTRUCTION MANUAL

RR-10 Manual Section & Pipe Rolling Machine 50 x 10mm Flat Bar



S681

GENERAL NOTES

1. Introduction

This manual is for your safety and is essential information for a long production life. As long as you keep up with our manual, you will be able to run your machine smoothly and safely. Keep in mind that the machine is designed for maximum safety and efficiency.

In this manual you can find instructions and information about:

- ◆ Correct installations of the machine
- ◆ Description of the functional parts of the machine
- ◆ Set-up and start-up adjustments
- ◆ Correct standard and scheduled maintenance
- ◆ Simple safety regulations and accident prevention

Possible risks connected with machine operation are pointed out as follows:

Attention: Shows the risks of accident, if instructions are not followed.

Warning: Shows the probable damages to the machine or equipment, if the instructions are not strictly followed.

Note: It gives useful information.

It is certainly necessary that the operator should read and understand all the ATTENTION, WARNING notes specified in this manual before operating machine and before any lubrication or maintenance intervention.

Safety must be your first concern during all steps of installation, operation and maintenance for the protection of yourself, other users and the service of the machine.

In case of any failure please first refer to this manual, and then if a solution can not be found contact first of all the distributor where you purchased our product. Do not forget to refer to the drawings and the number for any spare part needed or to define any problem. Make sure you have the serial number and production year of the machine. Our technical staff will do their best to help you in the most convenient way.

2. Transport

Remove any protective crates around the machine and read the instructions on related chapters of this manual carefully to set up the machine. If the machine is damaged in transport, immediately take photographs for insurance claims.

Take precautions while loading / unloading or moving the machine to avoid any injuries. Refer also to the related chapter of this manual for the best way of handing the machine.

3. Maintenance

Your machine is designed and produced to work efficiently and smoothly. To achieve this, you should also take care while operating the machine. Take heed of the maintenance sections to give your machine the longest possible life. Try and use original spare parts where necessary and most importantly do not overload the machine or do not make any unauthorized modifications.

4. Safety

Take all precautions possible to avoid any personal injury while using the machine. Keep in mind to protect the third party people around the machine. Refer to safety instructions.

GENERAL WARRANTY TERMS

- ◆ Your machine is covered by manufacturer's guarantee for a period of 12 months from the date of production against manufacture defects.
- ◆ The warranty covers only manufacture defective parts and / or components that are reported as "defective" by distributor, technician or the agent technician and must be reported to distributor in writing by fax or e-mail.
- ◆ The manufacturer is responsible for the supply of free of charge spares only and can not be held responsible for loss of work.
- ◆ Shipping and customs fees for the spare part must be paid by the end-user.
- ◆ A warranty claim does not relieve the customer from payment obligations.
- ◆ The customer can not ask or demand any reimbursement of damage nor the customer will have the right to extend or delay payment obligations nor the cancellation of order and the refunding of damages as the guarantee is given for the defective parts of the machine and not for the job.

Note: all warranty claims must include the model, serial number and the manufacture year of the machine.

GENERAL SAFETY TERMS

1. Machine's safety accessories and accident prevention terms

- ◆ No other persons except for a qualified and well-trained operator should be allowed to use the machine and be present in the working area of the machine
- ◆ Before making any modifications to change the machine's use, please contact to distributor, and ask their written approval.

2. Abnormal conditions

In order to avoid unusual working conditions, several recommendations to the operator are listed. Also, do not forget that this machine can be used only in the conditions presented in this operation and maintenance handbook.

- ◆ Avoid approaching the operator while the machine is running.
- ◆ Loading and unloading of the material should be done according to the instructions of this handbook.
- ◆ During the bending process avoid holding material by hand.
- ◆ Never wear garments with loose parts, which may become caught in the machine parts like necklaces, ring etc, and avoid long loose hair.
- ◆ Never use materials outside the operational specifications of the machine.
- ◆ Never run the machine without safety devices.
- ◆ Don't climb on the machine.
- ◆ If the customer wants to install a piece of equipment on the RBM-10, which has not been supplied

by us. compliance with the safety conditions explained here must be checked.

- ◆ The machine can not be installed and used in corrosive environments.
- ◆ The machine must always be operated with one qualified operator who has the required knowledge to use this machine properly.

TRANSPORTING, LIFTING AND CARRYING

Before preparing the machine for installation and start-up, a detailed visual account is required in order to detect any possible damages that occurred during transporting and handling. The distributor has to be informed of unexpected occurrence straight away.

If one or several parts of the machine have been damaged while shipping, the installation of the machine has to be suspended.

While lifting take care of these points:

- ◆ Always lift and carry the machine from the handles.
- ◆ Use a steel rope capable of carrying 167 kg.
- ◆ Take precautions for handing and lifting.
- ◆ Check if the load is properly balanced by lifting it an inch or two.
- ◆ Lift the machine, proceeding with care, without sudden accelerations or quick changes of directions.
- ◆ Place the machine where it must be installed lower the machine slowly till it touches the floor.

Figure 1 shows a way of carrying the machine. You can use a crane with hook or a forklift for handing operation.

Attention: Lifting and carrying operations should be carried out by skilled workers, such as truck operator, crane operator, etc. Also, it is necessary to keep in mind that having a large clearance area around the machine is important for efficient and safe working conditions.

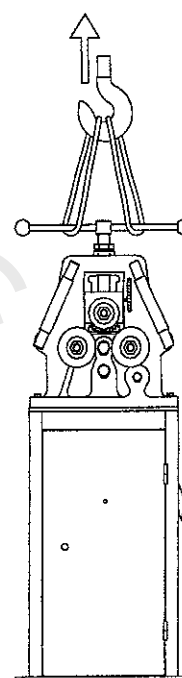

Figure 1

FOUNDATION AND MAIN DIMENSIONS OF THE MACHINE

For good operation, the machine needs to be bolted to the floor with anchor bolts as shown in figure 1. However, since the RBM-10 does not run at high operational speeds, it is not necessary to use technical devices to reduce the transmission of vibrations.

Note: for a correct operation the machine must be placed on a flat, preferably concrete base and even floor. Also, it must perfectly vertical.

Figure 1 and figure 2 show the main dimensions of the machine. Figure 3 shows the area into which anyone except for operator is forbidden to enter.

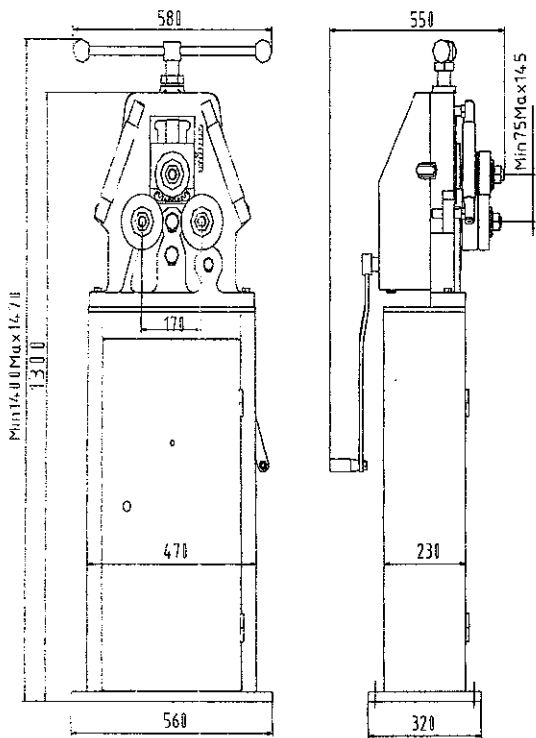

Figure 1

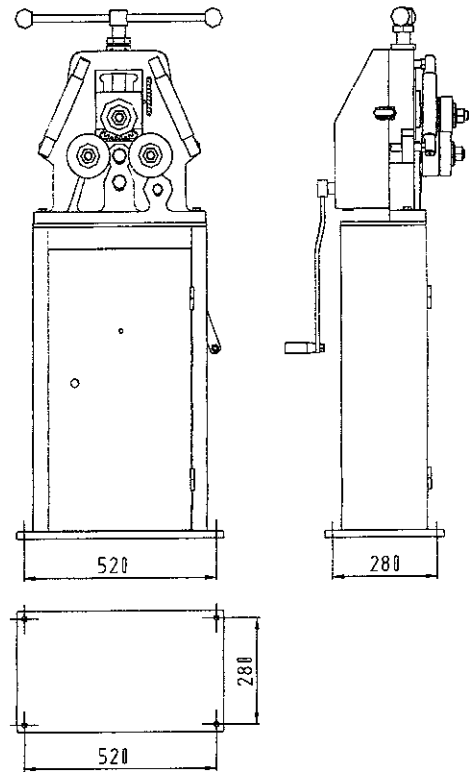

Figure 2

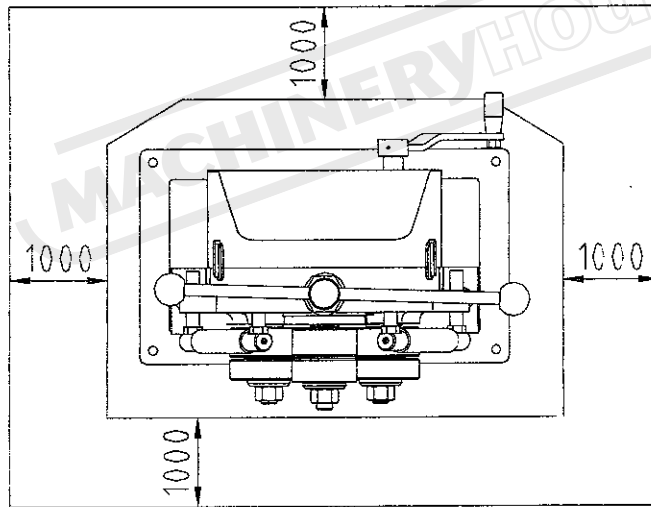

Figure 3

Note: The manufacturer does not accept any responsibility for damages due to the nonobservance of the listed specifications.

Note: All machines must be carefully adjusted before operation with a water gauge.

RBM-10's TECHNICAL PROPERTIES

Shaft diameters: \varnothing 1.18"

Lower rolls diameters: \varnothing 4.65"

Upper roll diameters: \varnothing 3.86"

Weight: 167.00 kg

Length: 58.00 cm

Width: 55.00 cm

Height: 147.00 cm

1. STANDARD SPECIFICATIONS

- ◆ Two rollers are manually powered
- ◆ Special cast frame
- ◆ Rolls shafts are special hardened steel
- ◆ Standard rolls, guide rolls
- ◆ Solid cast gears
- ◆ User's manual book

2. SPECIAL FEATURES









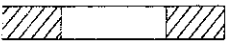
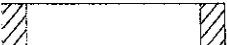
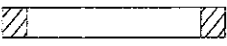
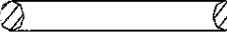

- ◆ Special rolls for pipe, tube and profile bending
- ◆ Extended roll shafts

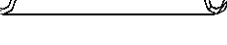
3. SAFETY UNITS

- ◆ Various DANGER signs around the machine

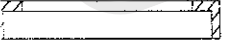
Note: Due to various safety regulations, the specifications presented here can change without prior notice. Above dimensions and other characteristics can also change without prior notice due to our constant improvements on our products.

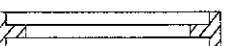
CAPACITY CHART FOR RBM-10

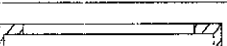
NO	Profile Type	Max	Min	Notes
1		0.78x0.19 1.18x0.39	7.5 19.685	Standard rools
2		0.78x0.19 1.96x0.39	6.25 15.748	Standard rools
3		0.39 0.78	6.28 19.685	Standard rools
4		0.39 0.78	6.28 19.682	Optional rools
5		0.984x0.59 1.18x0.78	15.748 31.496	Optional rools
6		3/4" 1"	19.685 27.559	Optional rools
7		1.18x0.59x0.59 1.5x0.78x0.78	23.622 39.37	Optional rools
8		0.787x0.787x0.078 1.181x1.181x0.078	23.622 35.433	Optional rools
9		1.181x1.181x0.157 1.37x1.37x0.157	15.748 31.496	Optional rools
10		N/A	N/A	Optional rools
11		1.181x1.181x0.157 1.37x1.37x0.177	15.748 23.622	Standard rools
12		1.181x1.181x0.157 1.37x1.37x0.177	15.748 23.622	Standard rools
13		1.181x1.181x0.177 1.574x0.787x0.196	19.685 27.559	Standard rools
14		1.181x0.59x0.177 1.574x0.787x0.196	19.685 27.559	Standard rools

Capacities are given for ST 42 material.

We reserve the right to make changes without notices.

Warning: Do not feed profiles having a higher thickness than specified for the capacity of the machine.

Do not feed more than one piece at a time.

Do not use the machine for any other scope the one for which it has been designed.

STANDARD ROLLER DIMENSIONS FOR RBM-10

TOP ROLL

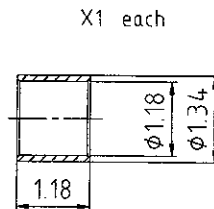
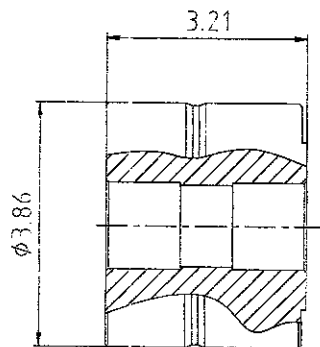

BOTTOM ROLLS

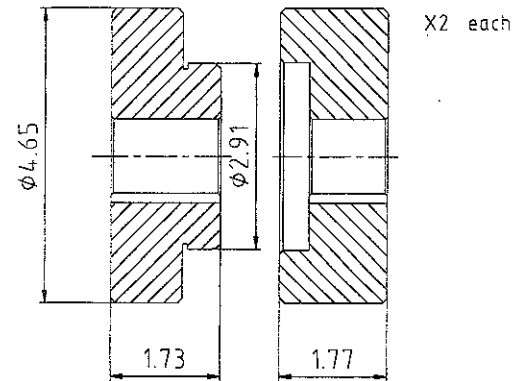

Figure 4

Roll material SAE 1050 hardened to > 56 HRC

Note: Special rollers are available from us.

START-UP INSTRUCTIONS

1. Materials and products

Although the machine is mainly steel, it is not designed for handling flammable or detrimental products. It is duty of the customer to check if the materials to be processed are potentially hazardous. Also, it is duty of the customer to check if the processed materials can be dangerous for the operator working nearby.

When selecting the most appropriate operation material you should keep in mind those instructions:

Material choice:

- ◆ Material must be clean of oil and dry. (without oil)
- ◆ Material should have a smooth surface so it processes correctly and easily.
- ◆ Material diameter must be regular and match the values explained in the instructions.
- ◆ Chemical structure of material must be homogenous and the hardness value must always be same throughout the material.
- ◆ We recommend you buy certificated steel.
- ◆ Material should also be bought from the same place when possible.

Note: The thorough cleaning of the rolls is absolutely necessary in order to avoid possible sliding of the profile due to grease residues on the rolls.

2. Operating the machine

The following rules must be applied for better productivity

- ◆ Select the relevant roll for material to be bent
- ◆ Place the material on lower rolls

- ◆ Move the upper roll down, by rotating hand-level placed at the top of machine, until the upper roll contacts to the material which will be bended.
- ◆ Begin rotating the lower rolls, by turning the hand lever arm that rotates the main powering shaft.
- ◆ Bending diameter is adjusted by positioning the upper roll at desired level.
- ◆ In the case of any distressed condition, you can immediately stop rotating the turning.
- ◆ It is possible to rotate lower rolls in two directions with the turning arm.

OPERATION

1. Operating instructions

Place the material on the roll flatly as shown in the figure 1. Make sure that material is placed parallel to the ground and touching all three rolls at the same time. This position is called "zero position".

Move the upper roll down like in figure 2 and position it to apply enough force to bend the material. Do not apply force more than necessary. If you apply too much force you may deflate the material during bending operation.

To get desired diameter make more than one pass by gradually lowering the upper roll after each pass. After a pass if the diameter value is bigger than expected, move the upper roll down to apply more force. If the opposite is the case, than move the upper roll upward using the milimetric ruler as a guide. (look at figure 3).

It is likely that the material will tend to bend right or left. To prevent this, you must adjust the guide rolls as shown in the figures 4 and 5.

As the guides are adjustable on top and bottom, you can arrange them to the opposite of material directional inclination.

Note: To get a circular profile, side guide joints must be parallel to the machine surface. Otherwise, you just get spiral profiles. Figure 6 shows bending operations for different kind of sections with special rolls.

In case of bending long materials, material feeder is advised to use in order to keep work piece parallel to the base ground (see figure 7). This will make it easier to bend such work pieces.

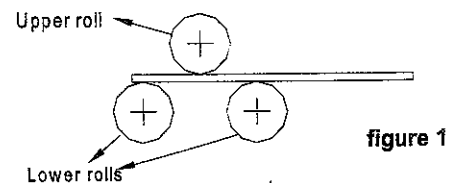

figure 1

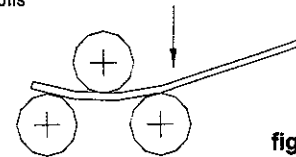

figure 2

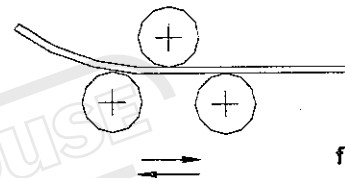

figure 3

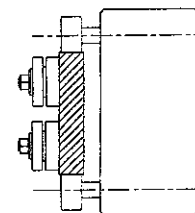

figure 4

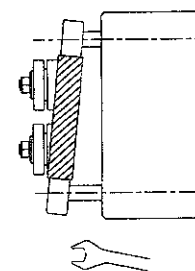

figure 5

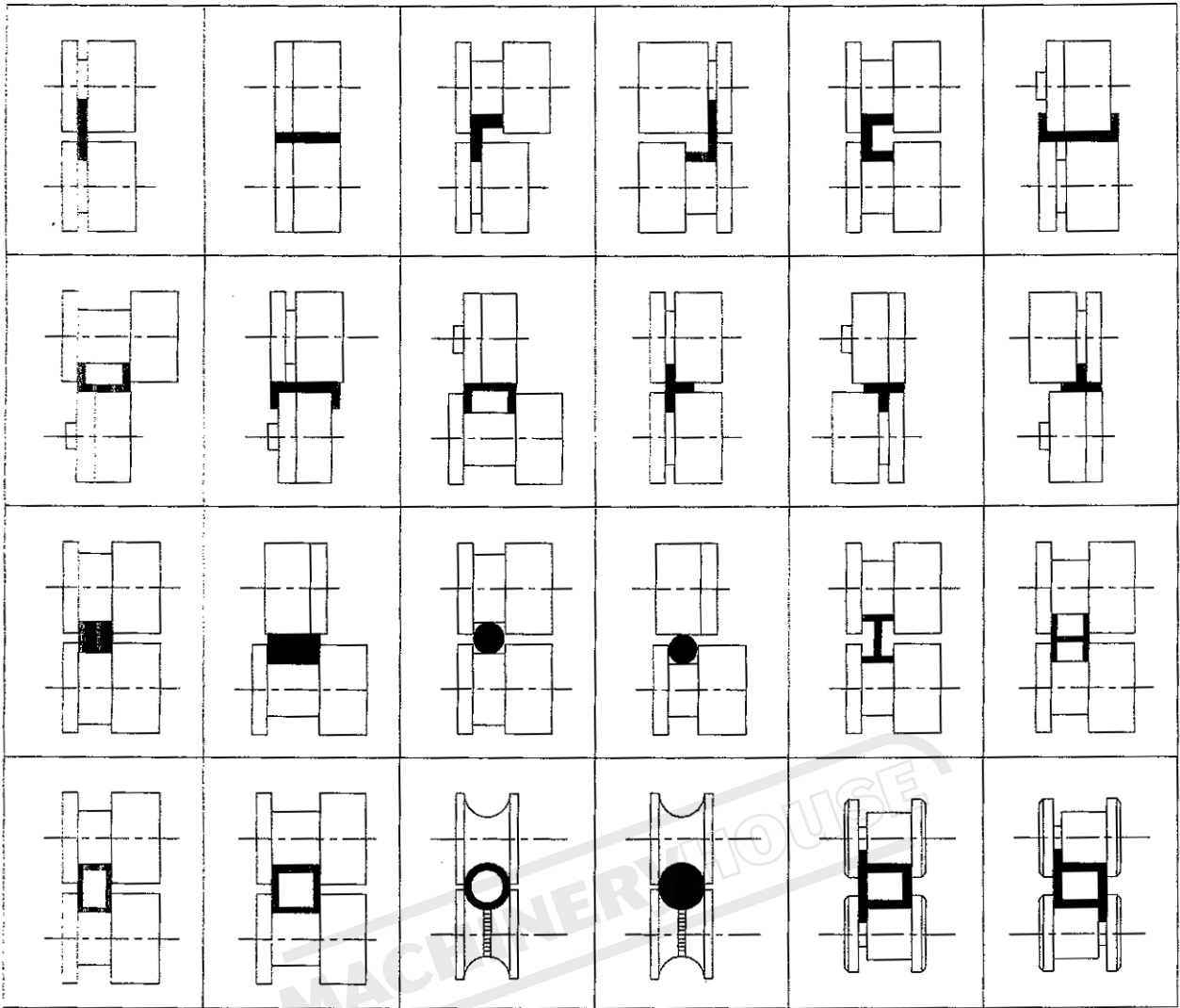

Figure 6

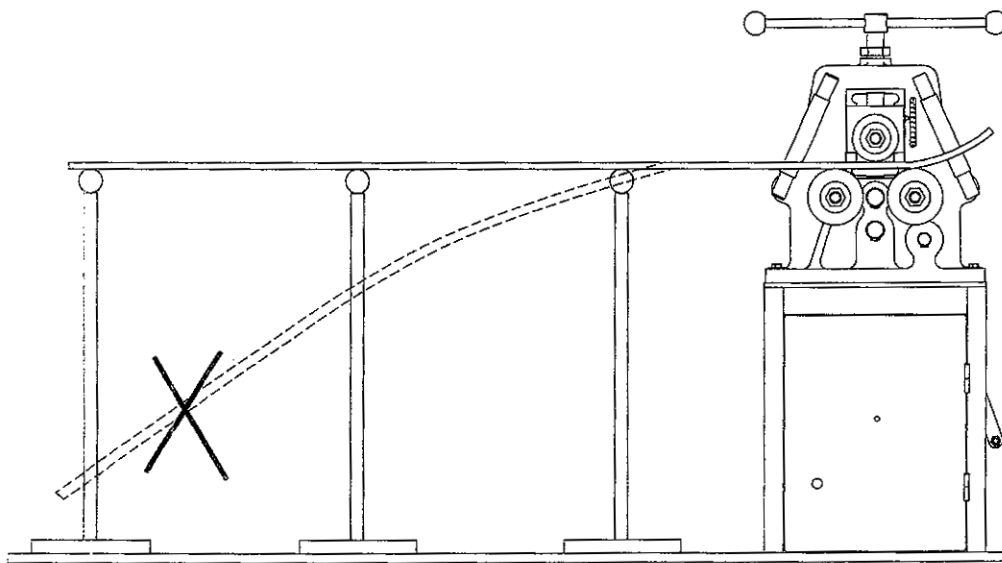

Figure 7

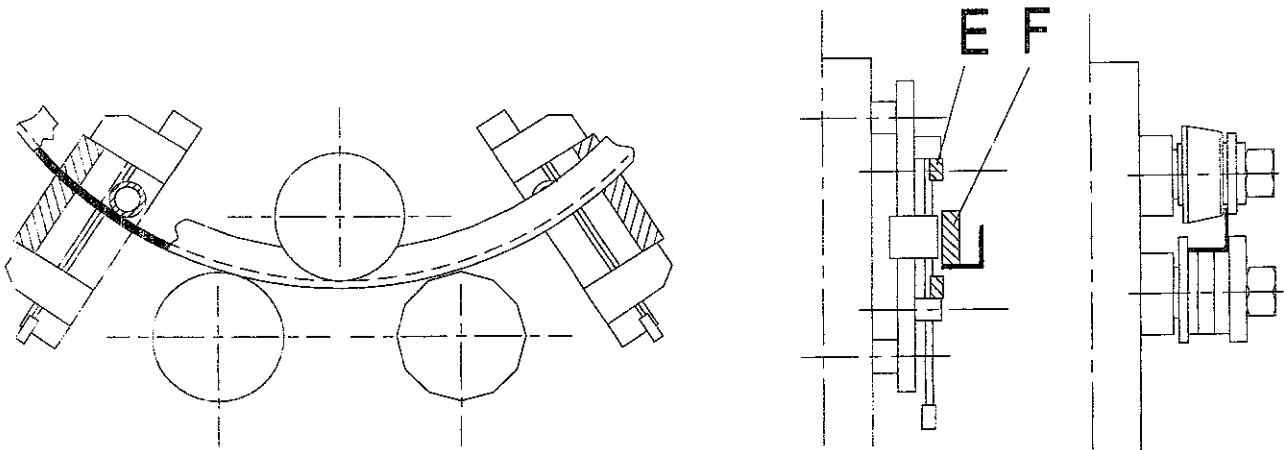

Figure 8

Figure 8 shows the use of "leg-in bending guide rolls". These guide rolls are an optional accessory for bending leg-in (angle) material. They are adjustable for any size of material and easy to use. Special rolls are recommended for any batch jobs of leg-out material. Some of the angle materials can be bent with standard rolls.

2. Operational hints

- ◆ Always clean the rolls and the material of dust, dirt and grease for bending.
- ◆ if you are bending a pipe do not rotate the pipe while bending.
- ◆ We advise you to fill the profiles or pipe with sand or any similar material if they have a wall thickness of less than 0.079".
- ◆ Do not overload the machine and use special rolls for profiles as well as pipes
- ◆ Operate safety keeping in mind the third party people around the machine
- ◆ Leave enough workspace around the machine.

MAINTENANCE

Regular maintenance should be performed by a well-trained mechanical engineer. Gears, shafts, parts under friction stress, and bearings should be greased once a month. Periodic lubricating can help the machine to have a long life and high productivity.

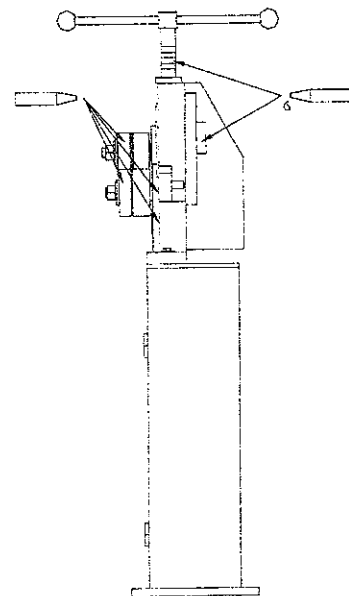

PARTS LIST

Part No.	Description	Qty	Part No.	Description	Qty
1	Stand	1	30	Middle bedding slide	2
2	Door	1	31	Lower roll	1
3	Washer 12	2	32	Bearing bushing	2
4	Bolt M12x45	2	33	Washer	3
5	Body	1	34	Nut M24	3
6	Lock buckle	2	35	Bolt M8x30	4
7	Shield	1	36	Washer	3
8	Spring pin 6x35	4	37	Main gear	2
9	Body	1	38	Retaining ring 35	4
10	Nut M36	1	39	Graphite bearing(1)	8
11	Bolt M5x10	4	40	Graphite bearing(2)	2
12	Side guide joint	4	41	Graphite bearing(2)	2
13	Side guide bolt	4	42	Key 8x30	4
14	Bearing	4	43	Key 8x63	2
15	Powering gear shaft	2	44	Lower roll	2
16	Side guide shaft	2	45	Middle gear shaft	1
17	Lever ball M12x50	4	46	Middle gear	1
18	Rotating lever	1	47	Washer	1
19	Turning shaft	1	48	Lower gear shaft	1
20	Bolt M12x30	1	49	Gear	1
21	Washer	1	50	Washer 25	1
22	Bolt	1	51	Graphite bearing(1)	2
23	Bolt M10x60	4	52	Graphite bearing(2)	1
24	Top roll shaft	1	53	Turning hand lever	1
25	Middle bedding	1	54	handle	1
26	Bolt M5x10	1	55	Bolt M6x12	1
27	Nut M8	4	56	Nut M12	1
28	Bolt M8x25	4	57	Hand bar holder	1
29	Finger	1	58	Scale	1

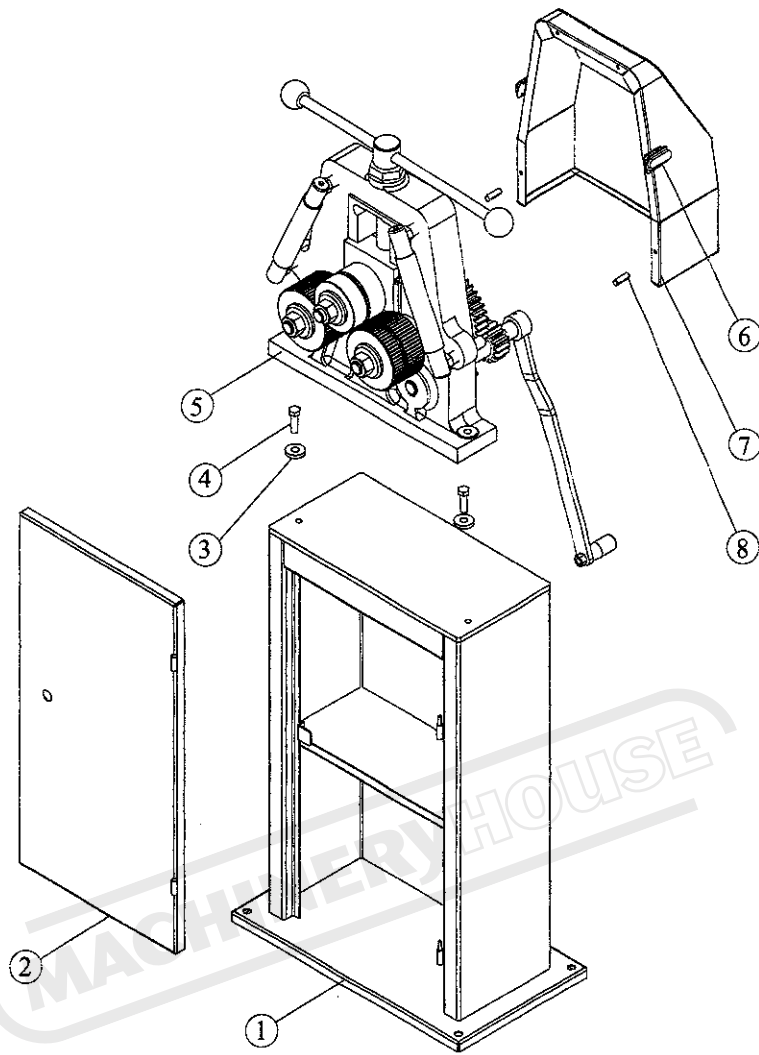

III

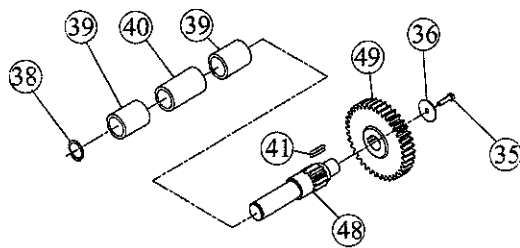

IV

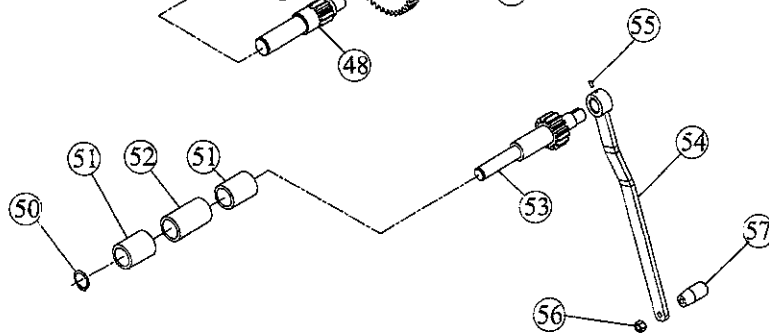

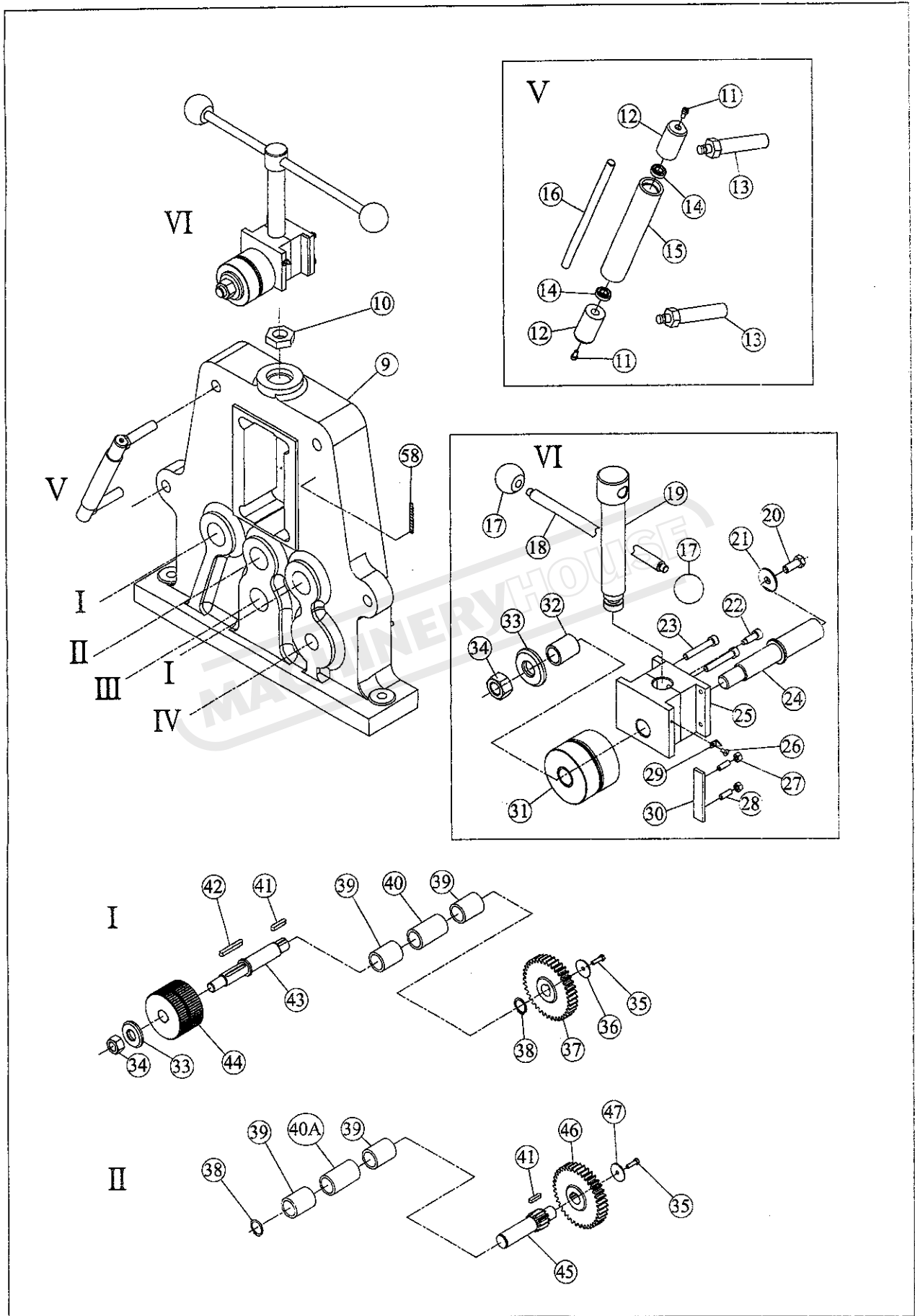

MACHINERYHOUSE

Note: This manual is only for your reference. Owing to the continuous improvement of the machine, changes may be made at any time without obligation on notice. And please note the local voltage while operating this electric machine.



WARNING

General Machinery Safety Instructions

Machinery House
requires you to read this entire Manual before using this machine.

- 1. Read the entire Manual before starting machinery.** Machinery may cause serious injury if not correctly used.
- 2. Always use correct hearing protection when operating machinery.** Machinery noise may cause permanent hearing damage.
- 3. Machinery must never be used when tired, or under the influence of drugs or alcohol.** When running machinery you must be alert at all times.
- 4. Wear correct Clothing.** At all times remove all loose clothing, necklaces, rings, jewelry, etc. Long hair must be contained in a hair net. Non-slip protective footwear must be worn.
- 5. Always wear correct respirators around fumes or dust when operating machinery.** Machinery fumes & dust can cause serious respiratory illness. Dust extractors must be used where applicable.
- 6. Always wear correct safety glasses.** When machining you must use the correct eye protection to prevent injuring your eyes.
- 7. Keep work clean and make sure you have good lighting.** Cluttered and dark shadows may cause accidents.
- 8. Personnel must be properly trained or well supervised when operating machinery.** Make sure you have clear and safe understanding of the machine you are operating.
- 9. Keep children and visitors away.** Make sure children and visitors are at a safe distance for you work area.
- 10. Keep your workshop childproof.** Use padlocks, Turn off master power switches and remove start switch keys.
- 11. Never leave machine unattended.** Turn power off and wait till machine has come to a complete stop before leaving the machine unattended.
- 12. Make a safe working environment.** Do not use machine in a damp, wet area, or where flammable or noxious fumes may exist.
- 13. Disconnect main power before service machine.** Make sure power switch is in the off position before re-connecting.
- 14. Use correct amperage extension cords.** Undersized extension cords overheat and lose power. Replace extension cords if they become damaged.
- 15. Keep machine well maintained.** Keep blades sharp and clean for best and safest performance. Follow instructions when lubricating and changing accessories.
- 16. Keep machine well guarded.** Make sure guards on machine are in place and are all working correctly.
- 17. Do not overreach.** Keep proper footing and balance at all times.
- 18. Secure workpiece.** Use clamps or a vice to hold the workpiece where practical. Keeping the workpiece secure will free up your hand to operate the machine and will protect hand from injury.
- 19. Check machine over before operating.** Check machine for damaged parts, loose bolts, Keys and wrenches left on machine and any other conditions that may effect the machines operation. Repair and replace damaged parts.
- 20. Use recommended accessories.** Refer to instruction manual or ask correct service officer when using accessories. The use of improper accessories may cause the risk of injury.
- 21. Do not force machinery.** Work at the speed and capacity at which the machine or accessory was designed.
- 22. Use correct lifting practice.** Always use the correct lifting methods when using machinery. Incorrect lifting methods can cause serious injury.
- 23. Lock mobile bases.** Make sure any mobile bases are locked before using machine.
- 24. Allergic reactions.** Certain metal shavings and cutting fluids may cause an allergic reaction in people and animals, especially when cutting as the fumes can be inhaled. Make sure you know what type of metal and cutting fluid you will be exposed to and how to avoid contamination.
- 25. Call for help.** If at any time you experience difficulties, stop the machine and call you nearest branch service department for help.

WARNING

Section Rolling Machine Safety Instructions

Machinery House
requires you to read this entire Manual before using this machine.

- 1. Maintenance.** Make sure the Section Rolling Machine is turned off and disconnect from the main power supply and make sure all moving parts have come to a complete stop before any inspection, adjustment or maintenance is carried out.
- 2. Section Rolling Machine Condition.** A Section Rolling Machine must be maintained for a proper working condition. Never operate a Section Rolling Machine that has damaged or worn parts. Scheduled routine maintenance should be performed on a scheduled basis.
- 3. Roll Condition.** Never operate a Section Rolling Machine with a damaged or badly worn roll. Replace if required. Rolls should never be greased or lubricated as rolls will slip the material and will not bend.
- 4. Roll Direction.** Be aware of the correct rotational axis of the motor when a qualified electrician connects the Machine.
- 5. Hand Hazard.** Keep hands and fingers clear from moving parts. Serious injury can occur if hand or finger tips get pinched by rolls and can be dragged into machine.
- 6. Personal Protection.** Gloves, safety glasses and safety hat are recommended during operation.
- 7. Avoiding Entanglement.** Section Rolling Machine guards must be used at all times. Tie up long hair and use the correct hair nets to avoid any entanglement with the Section Rolling Machine moving parts.
- 8. Understand the machines controls.** Make sure you understand the use and operation of all controls.
- 9. Trained Operator.** This machine must be operated by authorized and trained personnel.
- 10. Power outage.** In the event of a power failure during use of the machine, turn off all switches to avoid possible sudden start up once power is restored.
- 11. Work area hazards.** Keep the area around the Section Rolling Machine clean from oil, tools, chips. Pay attention to other persons in the area and know what is going on around the area to ensure unintended accidents.
- 12. Guards.** Do not operate Section Rolling Machine without the correct guards in place. Necessary guards protect you from injuries by worm-type gearbox and other gears. The only other area which needs to be carefully monitored during use is the rotational area of the rolls.
- 13. Material condition.** Material must be clean of oil and dry. Oily material can slip and will not bend.
- 14. Material hardness.** Make sure your hardness is the same throughout the material, we recommend that you use certified material. Never bend hard steel, glass or fragile material on this machine.
- 15. Feeding material.** Making a tight bend in one pass is not possible. Several passes are needed before you can achieve a certain radius. Tighter curves and full radius always need more passes.
- 16. Stopping the Rolls.** Do not stop or slow the rolls with your hand or workpiece. Allow the Section Rolling Machine to stop on its own.
- 17. Emergency stop.** Use the emergency stop button in case of any emergency.
- 18. Hearing protection and hazards.** Always wear hearing protection as noise generated from machine and workpiece can cause permanent hearing loss over time.
- 19. Call for help.** If at any time you experience difficulties, stop the machine and call your nearest branch service department for help.

PLANT SAFETY PROGRAM

NEW MACHINERY HAZARD IDENTIFICATION, ASSESSMENT & CONTROL

Section Rolling Machine

Developed in Co-operation Between A.W.I.S.A and Australia Chamber of Manufactures
This program is based upon the Australian Worksafe Standard for Plant(NOHSC:1010-1994)

Item No.	Hazard Identification	Hazard Assessment	Risk Control Strategies <small>(Recommended for Purchase / Buyer / User)</small>
A	ENTANGLEMENT CRUSHING	HIGH LOW	Eliminate, avoid loose clothing / Long hair etc. Secure & support work material. Ensure machine is bolted down.
C	CUTTING, STABBING, PUNCTURING.	MEDIUM	Isolate power to machine prior to any checks or maintenance being carried out. Do not adjust or clean until the machine has fully stopped. Wear gloves to prevent cuts from material.
D	SHEARING	MEDIUM	Isolate power to machine when checks or maintenance is being carried out. Make sure all guards are secured shut when machine is on. Hands should be kept clear of moving parts such as rolls etc.
F	STRIKING	MEDIUM	Ensure area is kept clear of material being rolled.
H	ELECTRICAL	MEDIUM	All electrical enclosures should only be opened with a tool that is not to be kept with the machine. Machine should be installed & checked by a Licensed Electrician.
O	OTHER HAZARDS, NOISE.	LOW	Wear hearing protection as required.
Plant Safety Program to be read in conjunction with manufactures instructions			



www.machineryhouse.com.au



www.machineryhouse.co.nz

Authorised and signed by:
Safety officer:

Manager:

.....

.....

Revised Date: Aug-08